

-1, -2, -3

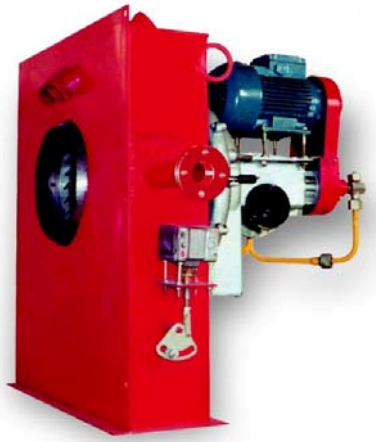

1. ;
2. (-1, -2, -3);
- 3.

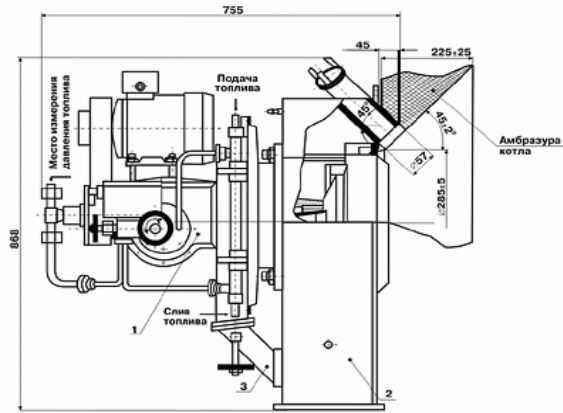

	-1, -1	-2, -2	-3, -
	1.1 ^{+0.11} _{-0.05}	2.2 ^{+0.22} _{-0.11}	3.5 ^{+0.35} _{-0.17}
	4		
	16±3,2	26±5.2	80±10
Q _H =40,53	98	196	310
	44		
Q _H =33,3 / ³	119	238	378
	1,22±0,24	3,15±0,63	2,5±0,3
	10 40		
	0 40		
	1,5		
	3000		
	380		
	220		
	755x758x870		755x878x870
	10585-75; Т 38-101656-87; 305-82; 5542-87		
	150		
с	185 609	185 609	223 159
	20±10 ; 20°		